

FEATURES

- Ultral wide input range: 34-160VDC
- Single and bipolar outputs: 5, 12, 15VDC
- 20W isolated output
- Efficiency up to 90%
- Six sides shielding
- Build-in EMI filter and input anti-reverse options
- Remote on/off control
- 1.5KVAC I/O isolation
- Operation case temperature:
-40°C to +105°C
- Standard 1.0"×1.0"×0.4" DIP footprint,
Din-rail & wall mount type options
- Extensive self-protection, UVLO, OTP,
OVP, OCP and short-circuit protection
- Outstanding thermal dissipation
- Fully encapsulated, high reliability
- MTBF ≥ 1 Mhrs
- Compliance with EN50155 standard

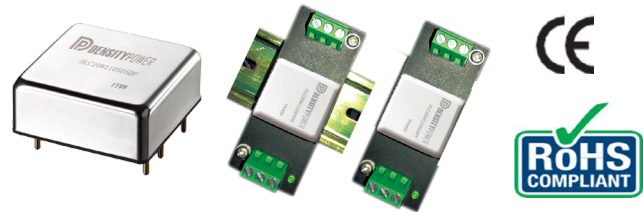

PRODUCT OVERVIEW

The DLC20W110 series use advanced power processing, control and packaging technologies to provide the high performance, flexibility, reliability and cost effectiveness of a mature power converter. Ultral wide range input of 34-160V (110V nominal) that complies with the European EN50155 standard for electronic equipment used on railway rolling stock. Fully encapsulated package technology provides outstanding thermal, vibration & shock performance, is ideal for railway applications where power modules must meet rugged environment requirements.

A wealth of self-protection features included input undervoltage lockout, over temperature shutdown, over current protection with "hiccup" autorestart technique, provides indefinite short-circuit protection, along with output OVP. The operation temperature is -40°C to 85°C, the module delivers full output power @ 105°C case temperature.

The DLC20W110 series are designed to railway standards EN 50155.

Models Selections

Basic Models	Input Voltage [VDC]	Input Voltage Range [VDC]	Output Voltage [VDC]	Output Current [A]	Efficiency Typ. [%]	Capacitive Load Max. [μF]	Package [inch]
DLC20W110S05	110	34-160	5	4	89	5000	1"×1"×0.4" DIP
DLC20W110S12	110	34-160	12	1.67	89	900	
DLC20W110S15	110	34-160	15	1.34	90	800	

Model Numbering

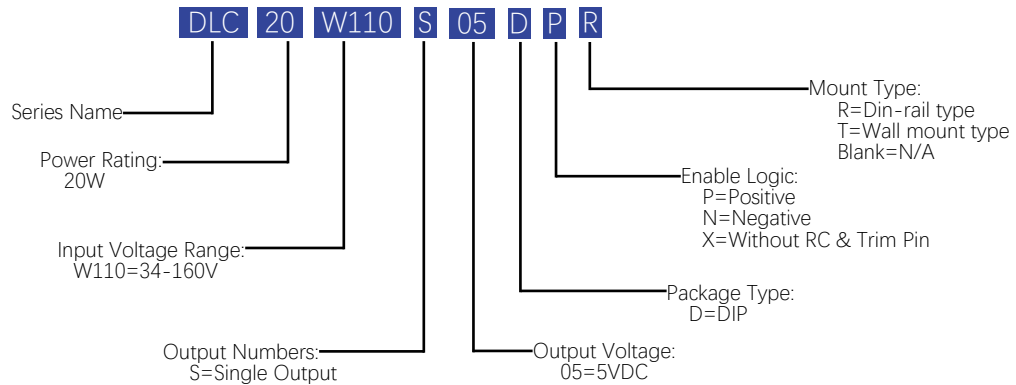

Absolute Maximum Ratings

Parameters	Conditions	Min.	Typ.	Max.	Units
Input Voltage Continuous		-0.5		160	VDC
Input Voltage Transient	< 100ms			180	VDC
On/Off Remote Control	Referred to -Vin			40	VDC
Remote Control Source Current		0		1.5	mA
Remote Control Sink Current		0		1.5	mA
Operating Case Temperature		-40		105	°C
Operating Environment Temperature	With derating	-40		85	°C
Storage Temperature Range		-55		125	°C
Soldering Temperature	Wave soldering < 10s			260	°C
Cooling	Free air convection				

Safety and EMC Compliance

Conducted Emission	EN50121-3-2		With external filter
Radiated Emission	EN50121-3-2		With external filter
Conducted Susceptibility	IEC6100-4-6		10Vrms Criteria A
Radiated Susceptibility	IEC6100-4-3		20V/m Criteria A
EFT	IEC6100-4-4	±2KV	Criteria A (With external filter)
Surge	IEC6100-4-5	±2KV	Criteria A (With external filter)
ESD	IEC6100-4-2	Contact: ±6KV	Air: ±8KV Criteria A
Isolation Safety Rating	Basic insulation		

Input Specifications					
Parameters	Conditions	Min.	Typ.	Max.	Units
Operating Voltage Range		34	110	160	VDC
Start-up Threshold		31		34	VDC
Under Voltage Shutdown		30		33	VDC
Recommended Input Fuse			2		A
General Specifications					
Parameters	Conditions	Min.	Typ.	Max.	Units
On/Off Remote Control	Positive Logic, On state	Open or $2.5 \leq V_r \leq 15$			VDC
	Positive Logic, Off state	Short or $0 \leq V_r \leq 0.8$			VDC
	Negative Logic, On state	Short or $0 \leq V_r \leq 0.8$			VDC
	Negative Logic, Off state	Open or $2.5 \leq V_r \leq 15$			VDC
Remote Control Current			1.0	2.0	mA
Isolation Voltage (Test for 1 minute)	Input to output	1500			VAC
	Input to case	1000			VAC
	Output to case	750			VAC
Isolation Resistance (Viso=500VDC)	Input to output	100			MΩ
Isolation Capacitance	Input to output		220		pF
Switching Frequency			300		KHz
Start-up Delay	From undervoltage shutdown recovery to 10% Vout		30		mS
Rise Time	From 10% Vout to 90% Vout capacitive load		30		mS
Vibration	IEC 60068-2-64, Environmental testing - Part 2				
Shock (Operational)	IEC 60068-2-27, Environmental Testing- Part 2.27				

All specifications are tested at 25 °C ambient temperature, nominal input voltage, rated output current conditions unless otherwise specified.

Performance Data (5 Vout Model)

Input Specifications

Parameters	Conditions	Min.	Typ.	Max.	Units
Input Reflected Ripple Current	Measured at input pin with 6.8 μ H inductor and 320 μ F capacitance		20		mA pk-pk
Input Current @ No Load				40	mA
Input Current @ Min. Line				0.9	A
Power Loss @ No Load				0.8	W
Recommended External Input Capacitance	1 μ F CBB and 100 μ F E-cap used in combination		100		μ F

Output Specifications

Parameters	Conditions	Min.	Typ.	Max.	Units
Output Voltage Setpoint	Nom.line, 50% load	4.95	5	5.05	VDC
Vout Accuracy		-1		+1	%
Line Regulation	Vin from min. line to max. line, 50% load	-0.2		+0.2	%
Load Regulation	From min. load to full load, Vin=nom.line	-0.5		+0.5	%
Temperature Coefficient	From -40 $^{\circ}$ C to 85 $^{\circ}$ C			0.02	% of Vout / $^{\circ}$ C
Total Regulation		-2		+2	%
Over Current Protection	Hiccup, auto-recover	110		200	%
Over Voltage Protection	Hiccup, auto-recover	115		160	%
Output Short Protection	Hiccup, auto-recover				
Ripple & Noise Max. ^①				100	mV Pk-Pk
Dynamic Load Peak Deviation ^②		-5		+5	% of Vout
Dynamic Load Response	within 1% band of Vout deviation			500	μ S
Capacitive Load		0		5000	μ F
Minimum Load	No minimum load required				

Notes

- ① Ripple & noise is tested with certain filter parameters, please see output ripple & noise in technical notes on page 13 for more details.
- ② Load is set from 50%-75%-50% of full load, di/dt=0.1A/ μ S, Cout=320 μ F.

Performance Data(5 Vout Model)

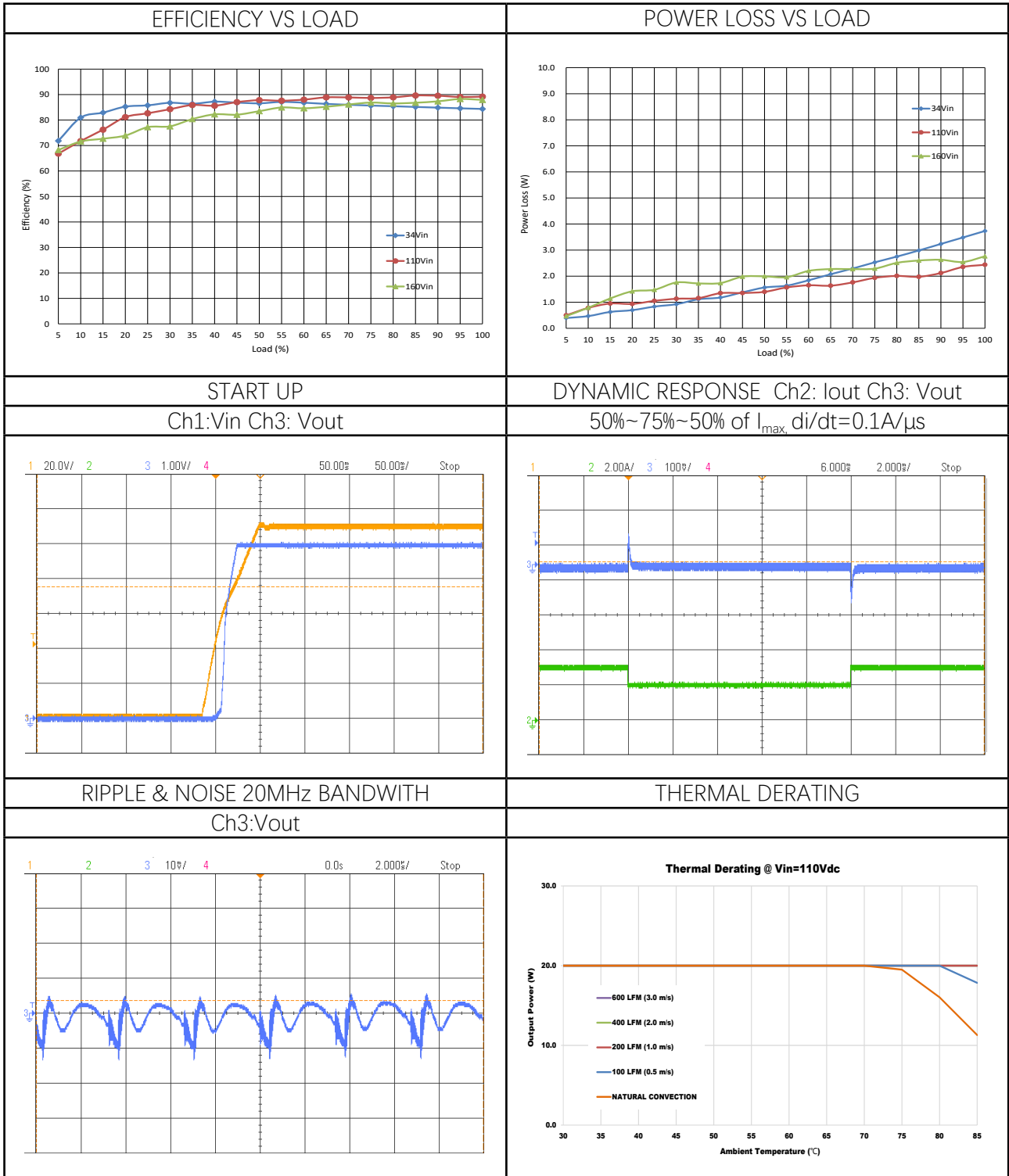

Performance Data (12 Vout Model)

Input Specifications					
Parameters	Conditions	Min.	Typ.	Max.	Units
Input Reflected Ripple Current	Measured at input pin with 6.8 μ H inductor and 320 μ F capacitance		35		mA pk-pk
Input Current @ No Load				40	mA
Input Current @ Min. Line				0.9	A
Power Loss @ No Load				0.8	W
Recommended External Input Capacitance	1 μ F CBB and 100 μ F E-cap used in combination		100		μ F
Output Specifications					
Parameters	Conditions	Min.	Typ.	Max.	Units
Output Voltage Setpoint	Nom.line, 50% load	11.88	12	12.12	VDC
Vout Accuracy		-1		+1	%
Line Regulation	Vin from min. line to max. line, 50% load	-0.2		+0.2	%
Load Regulation	From min. load to full load, Vin=nom.line	-0.5		+0.5	%
Temperature Coefficient	From -40°C to 85°C			0.02	% of Vout /°C
Total Regulation		-2		+2	%
Over Current Protection	Hiccup, auto-recover	110		200	%
Over Voltage Protection	Hiccup, auto-recover	115		160	%
Output Short Protection	Hiccup, auto-recover				
Ripple & Noise Max. ^①				100	mV Pk-Pk
Dynamic Load Peak Deviation ^②		-5		+5	% of Vout
Dynamic Load Response	within 1% band of Vout deviation			500	μ S
Capacitive Load		0		900	μ F
Minimum Load	No minimum load required				
Notes					
<p>① Ripple & noise is tested with certain filter parameters, please see output ripple & noise in technical notes on page 13 for more details.</p> <p>② Load is set from 50%-75%-50% of full load, di/dt=0.1A/μS, Cout=320μF.</p>					

Performance Data(12 Vout Model)

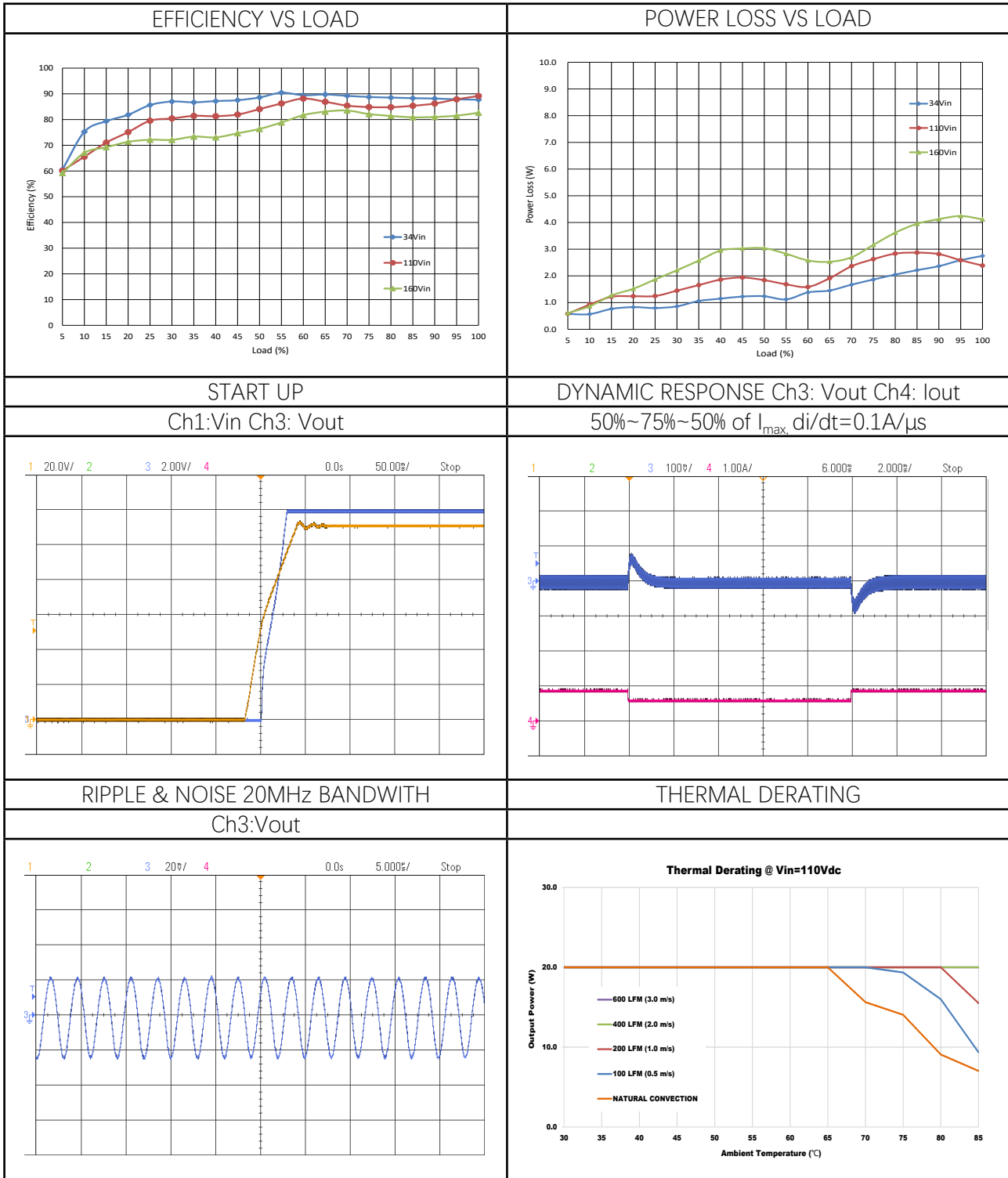

Performance Data (15 Vout Model)

Input Specifications					
Parameters	Conditions	Min.	Typ.	Max.	Units
Input Reflected Ripple Current	Measured at input pin with 6.8μH inductor and 320μF capacitance		35		mA pk-pk
Input Current @ No Load				40	mA
Input Current @ Min. Line				0.9	A
Power Loss @ No Load				0.8	W
Recommended External Input Capacitance	1μF CBB and 100μF E-cap used in combination		100		μF
Output Specifications					
Parameters	Conditions	Min.	Typ.	Max.	Units
Output Voltage Setpoint	Nom.line, 50% load	14.85	15	15.15	VDC
Vout Accuracy		-1		+1	%
Line Regulation	Vin from min. line to max. line, 50% load	-0.2		+0.2	%
Load Regulation	From min. load to full load, Vin=nom.line	-0.5		+0.5	%
Temperature Coefficient	From -40°C to 85°C			0.02	% of Vout /°C
Total Regulation		-3		+3	%
Over Current Protection	Hiccup, auto-recover	110		200	%
Over Voltage Protection	Hiccup, auto-recover	115		160	%
Output Short Protection	Hiccup, auto-recover				
Ripple & Noise Max. ^①			130	200	mV Pk-Pk
Dynamic Load Peak Deviation ^②		-5		+5	% of Vout
Dynamic Load Response	within 1% band of Vout deviation			500	μS
Capacitive Load		0		800	μF
Minimum Load	No minimum load required				
Notes					
<p>① Ripple & noise is tested with certain filter parameters, please see output ripple & noise in technical notes on page 13 for more details.</p> <p>② Load is set from 50%-75%-50% of full load, di/dt=0.1A/μS, Cout=320μF.</p>					

Performance Data(15 Vout Model)

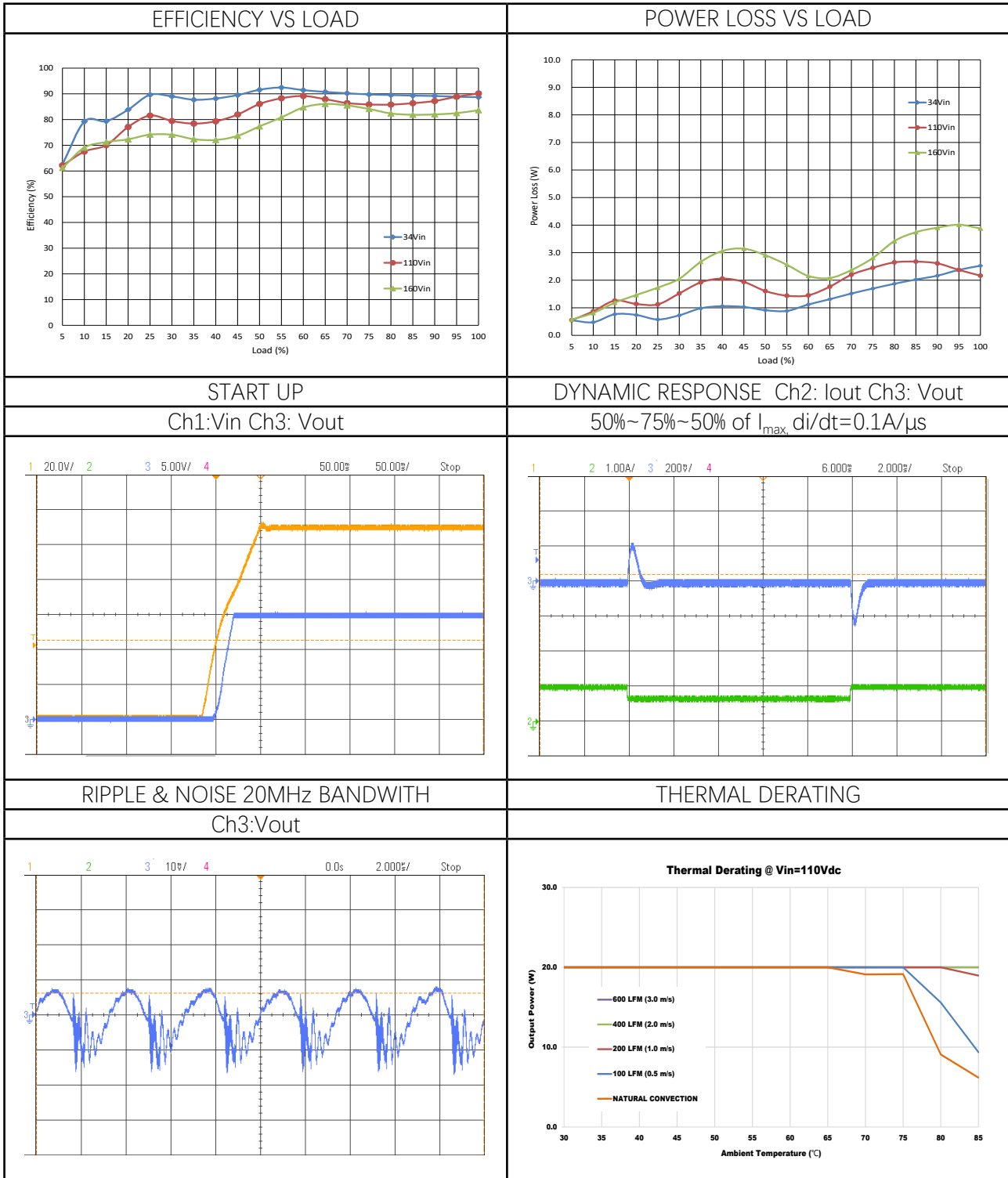

Mechanical Specifications

DLC20W110 SERIES: DIP TYPE

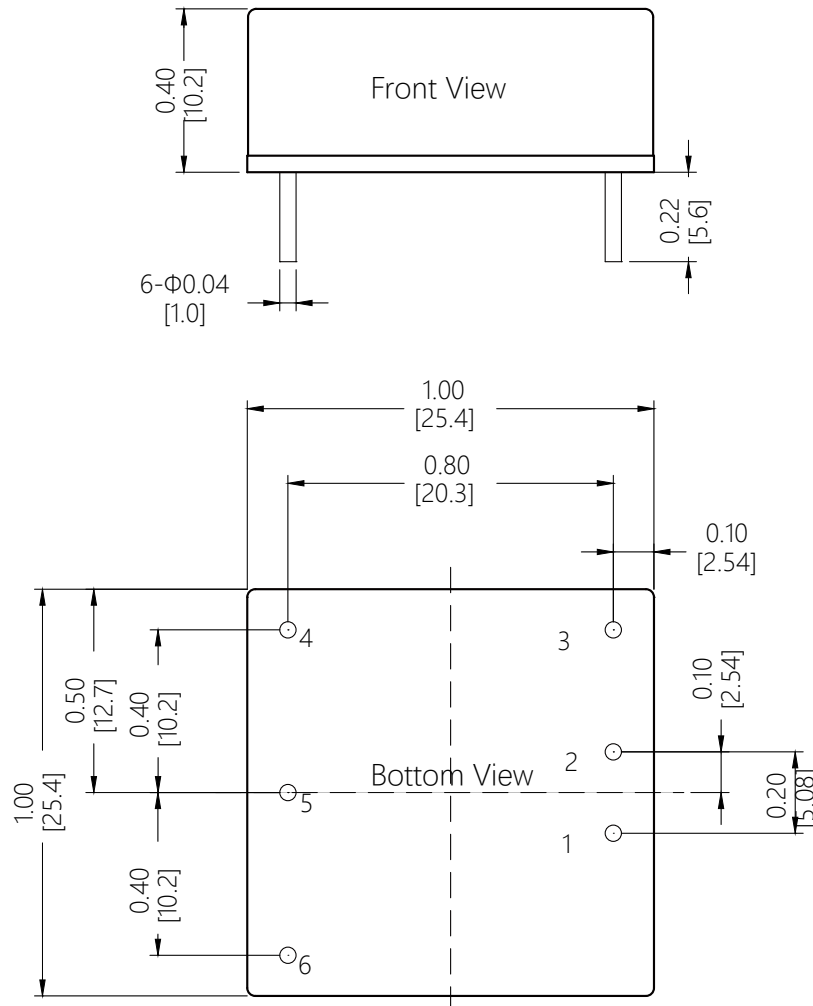

PIN:

Pin1, PIN2, PIN3, PIN4, PIN5, PIN6: Φ 0.040
 Force: Applied force not exceed 4.9N
 Material: Copper alloy
 Finish: Gold 3 ~ 5 μ m(min.) over nickel 50 μ m(Min.)

TOLERANCE:

X.XX= \pm 0.02 (0.5)
 X.XXX= \pm 0.010 (0.25)

Dimensions are in inches [mm]

Weight: ~20g.

Note1: Model number with suffix "X" is without RC & TRIM Pin.

PIN CONNECTIONS

Single Output	
Pin	Function
1	+Vin
2	-Vin
3	RC ⁽¹⁾
4	-Vout
5	TRIM
6	+Vout

Mechanical Specifications

DLC20W110 SERIES: DIN-RAIL TYPE

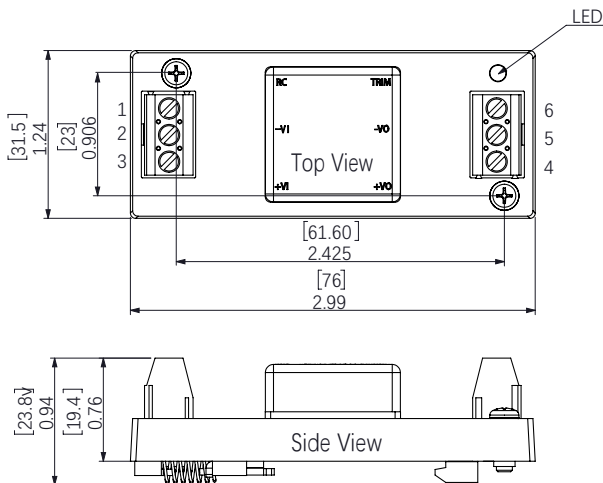

DLC20W110 SERIES: WALL MOUNT TYPE

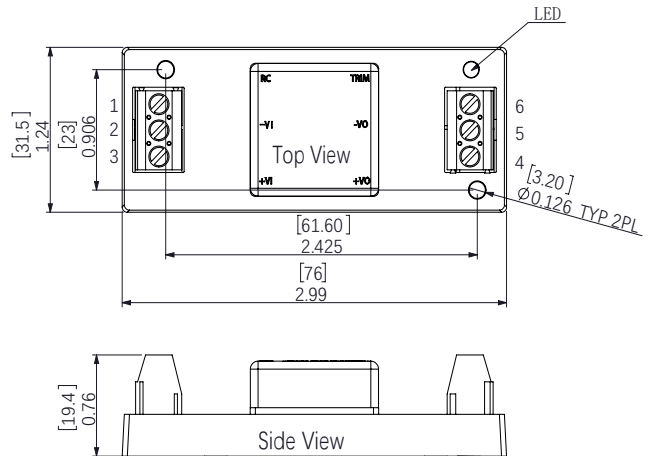

Hole screw locked torque: 0.4N·m Max
Terminal screw locked torque: 0.25N·m Max

Tolerance:
X.XX=±0.02 (0.5)
X.XXX= ±0.010 (0.25)

Dimensions are in inches [mm]

Weight:
Din-rail Type: ~65g
Wall Mount Type: ~45g.

Note1: Model number with suffix "X" is without RC & TRIM Pin.

PIN CONNECTIONS	
Single Output	
Pin	Function
1	RC ^①
2	-Vin
3	+Vin
4	+Vout
5	-Vout
6	TRIM

Technical Notes

INPUT FUSING

Certain applications may require fuse at the inputs of power conversion components. Fuses should also be used when there is possibility of sustained input voltage reversal which is not current limited. The DLC20W110 modules are not internally fused. We strongly recommend a slow-blown fuse to be used in the ungrounded input supply line. For safety agency approvals, the installer must install the converter in compliance with the end user safety standard.

TYPICAL APPLICATION CONNECTION

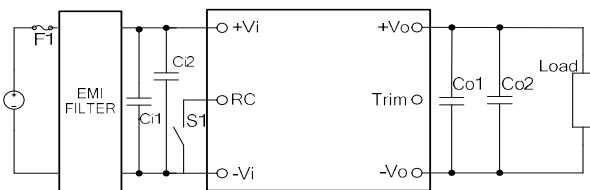

Figure 1: Typical Application Connection

In order to prevent the input line from causing the input oscillation, it is recommended to add the input capacitor close to the input of the module. Similarly, the output capacitor is added to the output of the module. Specific recommended parameters: input capacitance $C_{i1}=47\sim 100\mu\text{F}$ electrolytic capacitor. For output Capacitance, recommended value is $100\mu\text{F}/\text{A}$ (The current here refers to the output current).

REFLECTED RIPPLE CURRENT

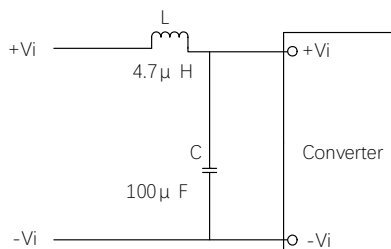

Figure 2: Reflected Ripple Current

Add LC filter at the front of the power module to

reduce the interference of reflected ripple current on the DC bus, recommended value of L and C with appropriate current and voltage rating as below: $L=4.7\mu\text{H}$; $C=100\mu\text{F}$.

CURRENT LIMITING

The output voltage remains constant as the output current increases. However, once the output current is over the specified Output DC Current Limit, the converter turns off.

The converter then enters into "hiccup mode" where it repeatedly turns on and off until the short circuit condition is removed. This prevents excessive heating of the converter or the load board.

REMOTE CONTROL FUNCTION

Module Power Remote Control or called ON/OFF pin is for the user to enable or disable the output. Control use high and low level control, there are two general control logic, positive logic or negative logic control. Recommend to use optocoupler to control ON/OFF Pin as below.

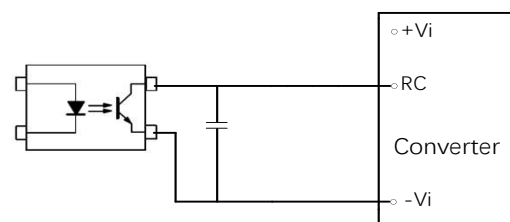

Figure 3: Remote Control

Remote Control Pin can be connected in parallel for multiple converters which with the same Remote Control characters. However, when several converters share the same remote control circuits, the total sink and source current must be taken into consideration, and make sure that the optocoupler has enough drive capability. To reduce external PCB trace interference, it is recommended to add high frequency bypass capacitor between RC pin and -Vi, recommended capacitor value is 100-1000pF.

Technical Notes

OUTPUT RIPPLE & NOISE

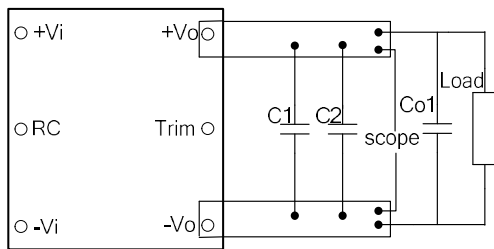

Figure 4: Output Ripple & Noise

These DLC20W110 modules' output ripple and noise is measured at the rated input voltage and output current, along with 10uF and 0.1uF MLCC used in parallel with appropriate voltage ratings and placed as C1,C2 shown in the figure above. The scope's bandwidth is set to 20MHz.

External output capacitors are required to reduce the ripple & noise. The output capacitors should be low ESR and appropriate frequency response with appropriate voltage ratings, and must be located as close to the converters as possible, also PCB layout must be taken into consideration.

INPUT UNDERVOLTAGE SHUTDOWN AND START-UP THRESHOLD

Once operating, module will not turn off until the input voltage drops below the Undervoltage Shutdown threshold. Subsequent re-start will not occur until the input is brought back up to the Start-Up Threshold. This built in hysteresis prevents any unstable on/off situations from occurring at a single input voltage.

SHORT CIRCUIT CONDITION

When the converter is in current-limit mode, the output voltage will drop as the output current demand increases and then the converter will be shut down. If the short-circuit condition persists, another shutdown cycle will be initiated. This on/off cycling is referred to as "hiccup" mode. The hiccup cycling reduces the average output current, thereby preventing internal temperatures from

rising to excessive levels. The module is capable of enduring an indefinite short circuit output condition.

OUTPUT OVERVOLTAGE PROTECTION

DLC20W110 output voltages are monitored for an overvoltage condition via magnetic feedback. The signal is coupled to the primary side and if the output voltage rises to a level which could be damaging to the load, the sensing circuitry will power down the PWM controller causing the output voltages to decrease. Following a time-out period the PWM will restart, causing the output voltages to ramp to their appropriate values. If the fault condition persists, and the output voltages again climb to excessive levels, the overvoltage circuitry will initiate another shutdown cycle.

THERMAL SHUTDOWN

These DLC20W110 converters are equipped with thermal-shutdown circuitry. If environmental conditions cause the internal temperature of the DC-DC converter to rise above the designed operating temperature, a precision temperature sensor will power down the unit. When the internal temperature decreases below the threshold of the temperature sensor, the unit will auto restart.

TRIMMING OUTPUT VOLTAGE

The DLC20W110 converters have a trim capability that allows users to adjust the output voltages. Output voltage can be trimmed up or down by a trim pin by connecting a single fixed resistor between Trim Pin and +Vo or -Vo, the output voltage can be increased or decreased depending on its connection. The maximum output voltage adjustment range is -10% to +10%. If the trim function is not used, keep TRIM pin floating.

Trim up:

Increase the output voltage by connecting an appropriate value resistor between Trim Pin and +Vo Pin. Show as below:

Technical Notes

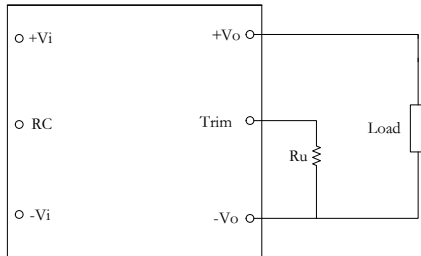

Figure 5· Trim Up Connection

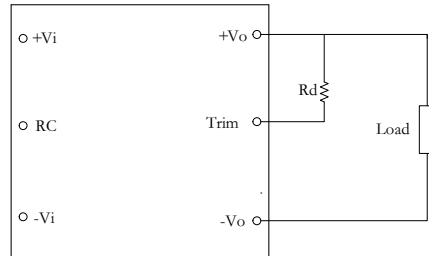

Figure 6· Trim Down Connection

Please follow up the Trim Up formula to calculate the resistor value according to the desired output voltage.

Please follow up the Trim Down formula to calculate the resistor value according to the desired output voltage.

$$5V: R_u = (10.01 \times \frac{0.5}{\Delta} - 36)(k\Omega)$$

$$5V: R_d = (10.01 \times \frac{0.5 - \Delta}{\Delta} - 36)(k\Omega)$$

$$12V: R_u = (28.5 \times \frac{0.506}{\Delta} - 100)(k\Omega)$$

$$12V: R_d = (29.2 \times \frac{0.506 - \Delta}{\Delta} - 100)(k\Omega)$$

$$15V: R_u = (30 \times \frac{0.5}{\Delta} - 100)(k\Omega)$$

$$15V: R_d = (30.1 \times \frac{0.5 - \Delta}{\Delta} - 100)(k\Omega)$$

"Δ" is the change of output voltage, such as: 5V output is raised to 5.5V,
 $\Delta = (5.5-5) / 5 * 100\% = 10\%$.

"Δ" is the amount of change in output voltage, such as: 5V output is reduced to 4.5V,
 $\Delta = (5-4.5) / 5 * 100\% = 10\%$.

Trim down:

Decrease the output voltage by connecting an appropriate value resistor between Trim Pin and -Vo Pin. Show as below:



This product is subject to the following operating requirements and the Life and Safety Critical Application Sales Policy:

Refer to: <http://www.densitypower.com>

Density Power makes no representation that the use of its products in the circuits described herein, or the use of other technical information contained herein, will not infringe upon existing or future patent rights. The descriptions contained herein do not imply the granting of licenses to make, use, or sell equipment constructed in accordance therewith. Specifications are subject to change without prior notice.