

4:1 Wide Input, Isolated 15Watts DC/DC Converters

FEATURES

- 4:1 wide input range: 9-36VDC
- Single & bipolar outputs: 5, 12, 13.5, ±15Volts DC
- 15W isolated outputs
- Efficiency up to 90%
- Six sides shielding
- Build-in EMI filter and input anti-reverse options
- Fixed switching frequency
- Remote on/off control
- 1600VDC I/O isolation
- Standard 1.25"×0.8"×0.4" footprint, Din-rail & wall mount type options
- Extensive self-protection, UVLO, OTP, OVP, OCP and short protection
- Operation temperature range: -40°C to +105°C
- Fully encapsulated, high reliability
- MTBF ≥ 1 Mhrs



PRODUCT OVERVIEW

The DKC15W24 series are highly reliable, and efficient isolated DC/DC converter. Wide input range of 9-36V(24V nominal) is ideal for automation, power grid, railway, semiconductor equipment, instrumentation, test and measurement, and distribution power system.

A wealth of self-protection features included input under-voltage lockout, over temperature shutdown; overcurrent protection with "hiccup" autorestart technique, provides short-circuit protection, along with output OVP. The operation temperature is -40°C to 105°C, the module delivers full output power @ 105°C case temperature.

Advanced fully encapsulated package technology with six sides shielding and build-in EMI filter provides outstanding EMC and thermal performance, which is ideal for ruggedized applications involving harsh environments. Wall mount and Din-rail mount type are available for maximum design-in flexibility.

The DKC15W24 series are designed to safety standards UL62368-1.

Models Selections

Basic Models	Input Voltage [VDC]	Input Voltage Range [VDC]	Output Voltage [VDC]	Output Current [A]	Efficiency Typ. [%]	Capacitive Load Max. [µF]	Package [inch]
DKC15W24S05	24	9-36	5	3	90	3300	1.25"×0.8"×0.4" DIP
DKC15W24S12	24	9-36	12	1.25	90	600	
DKC15W24S13	24	9-36	13.5	1.12	90.5	600	
DKC15W24B15	24	9-36	±15	±0.5	90	±200	

Model Numbering

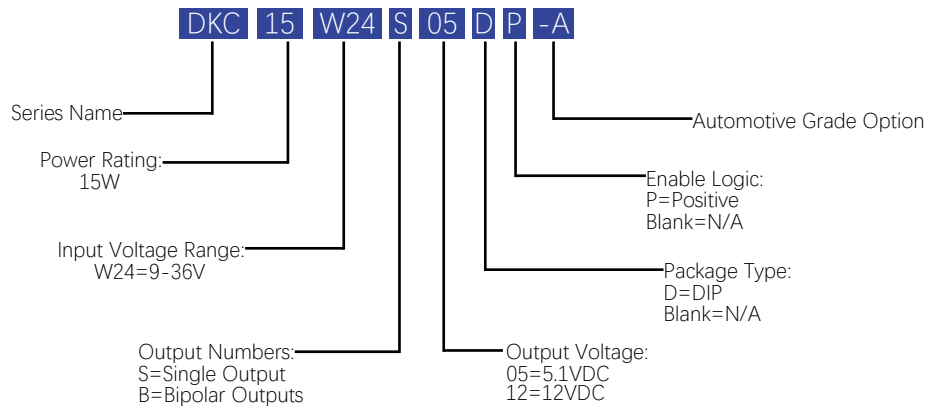

Absolute Maximum Ratings					
Parameters	Conditions	Min.	Typ.	Max.	Units
Input Voltage Continuous		-0.7		40	VDC
Input Voltage Transient	< 100ms			50	VDC
On/Off Remote Control	Referred to -Vin			40	VDC
Remote Control Source Current		0		1.5	mA
Remote Control Sink Current		0		1.5	mA
Operating Case Temperature		-40		105	°C
Operating Environment Temperature		-40		85	°C
Storage Temperature Range		-55		125	°C
Soldering Temperature	Wave soldering < 10s			300	°C
Safety and EMC Compliance					
Conducted Emission	EN55022	Class B (With external filter)			
Radiated Emission	EN55022	Class B (With external filter)			
Conducted Susceptibility	IEC6100-4-6	10Vrms Criteria A			
Radiated Susceptibility	IEC6100-4-3	10V/m Criteria A			
EFT	IEC6100-4-4	±2KV Criteria A (With external filter)			
Surge	IEC6100-4-5	±2KV Criteria A (With external filter)			
ESD	IEC6100-4-2	Contact: ±6KV Air: ±8KV Criteria A			
Isolation Safety Rating	Basic insulation				

General Specifications					
Parameters	Conditions	Min.	Typ.	Max.	Units
Isolation Voltage (Test for 1 minute)	Input to output	1600			VDC
	Input to case	1600			VDC
	Output to case	1000			VDC
Isolation Resistance (Viso=500VDC)	Input to output	100			MΩ
Isolation Capacitance	Input to output		1000		pF
Switching Frequency			330		KHz
Start-up Delay	From undervoltage shutdown recovery to 10% Vout			30	mS
Rise Time	From 10% Vout to 90% Vout capacitive load			20	mS
Remote On/Off Control	Positive Logic, ON state	3		15	VDC
	Positive Logic, OFF state	0		0.7	VDC
Vibration	IEC 60068-2-64, Environmental testing - Part 2				
Shock (Operational)	IEC 60068-2-27, Environmental Testing- Part 2.27				
Input Specifications					
Parameters	Conditions	Min.	Typ.	Max.	Units
Operating Voltage Range		9	24	36	VDC
Start-up Threshold		8		9	VDC
Under Voltage Shutdown		7.5		8.5	VDC
Input Current @ No Load			6	20	mA
Input Current @ Min. Line				2.2	A
Input Current @ Shutdown Mode			2	10	mA
Reflected Input Ripple Current (Peak-Peak)			20		mA
Power Loss @ No Load				1	W
Recommended Input Fuse				5	A
Recommended External Input Capacitance	1μF CBB and 100μF E-cap used in combination		100		μF
Output Specifications					
Parameters	Conditions	Min.	Typ.	Max.	Units
Output Power				15	W
Vout Accuracy	50% Load, Vin=24V	-1.0		+1.0	%
Line Regulation		-0.2		+0.2	%
Load Regulation	No load to full load	-0.5		+0.5	%
Cross Regulation	One output @50% FL, the other output is from 10% to 100% FL	-5.0		+5.0	%
Total Regulation		-2.5		+2.5	%

Output Specifications					
Parameters	Conditions	Min.	Typ.	Max.	Units
Temperature Coefficient		-0.02		+0.02	% of Vout /°C
Thermal Shutdown	Case temperature	110	115	120	°C
Thermal Shutdown Recover	Case temperature	85	95	105	°C
Over Voltage Protection	Hiccup, Auto-recover	110		140	%
Over Current Protection	Hiccup, Auto-recover	110		200	%
Short Circuit Protection	Hiccup, Auto-recover				
Minimum Load	No minimum load required				
Output Specifications					
Parameters	Modules				
	S05	S12	S13	B15	
Output Voltage Normal(VDC)	5.1	12	13.5	±15	
Ripple & Noise Max. (mV pk-pk) ^①	150	150	150	150	
Dynamic Load Peak Deviation Max.(%Vout) ^②	±5	±5	±5	±5	
Dynamic Load Response Max. (µS)	500	500	500	500	
Notes					
<p>① Ripple & noise is tested with certain filter parameters, please see output ripple & noise in technical notes on page 11 for more details.</p> <p>② For single output types, load is set from 50%-75%-50% of full load, di/dt=1A/µS, Cout=100µF; for bipolar output types, load is set in same condition in both output, Please refer to dynamic waveforms in performance data for details.</p>					

All specifications are tested at 25 °C ambient temperature, nominal input voltage, rated output current conditions unless otherwise specified.

Performance Data

EFFICIENCY VS LOAD

DKC15W24S05

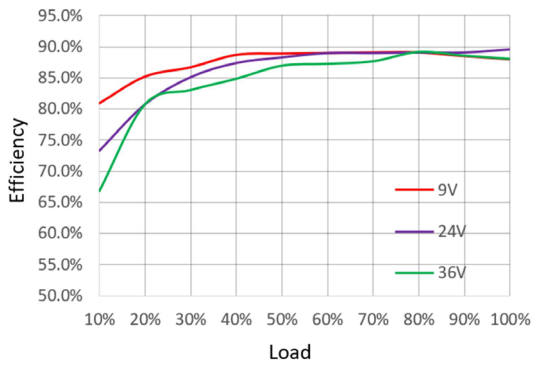

DKC15W24S12

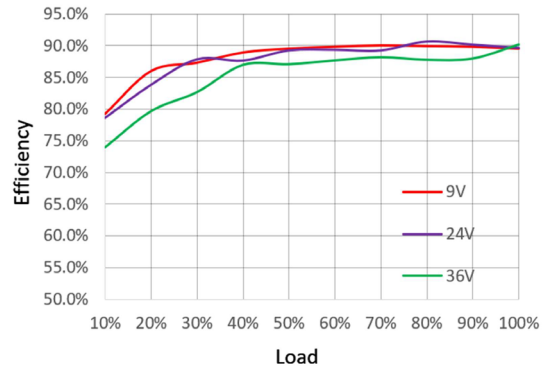

DKC15W24S13

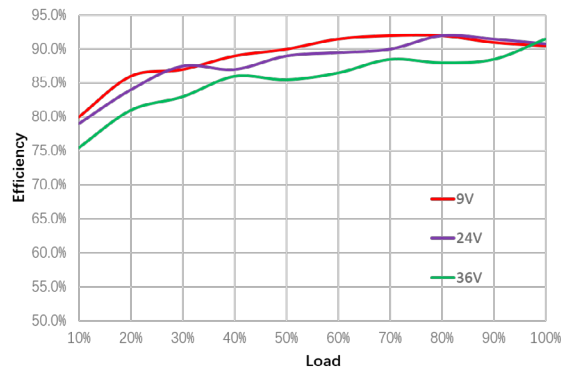

DKC15W24B15

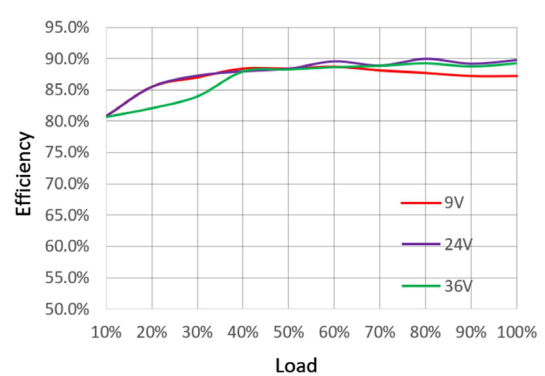

START UP Ch1: V_{in} Ch2: V_{out}

DKC15W24S05

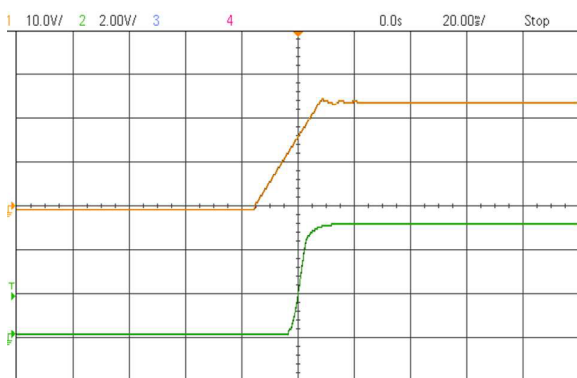

DKC15W24S12

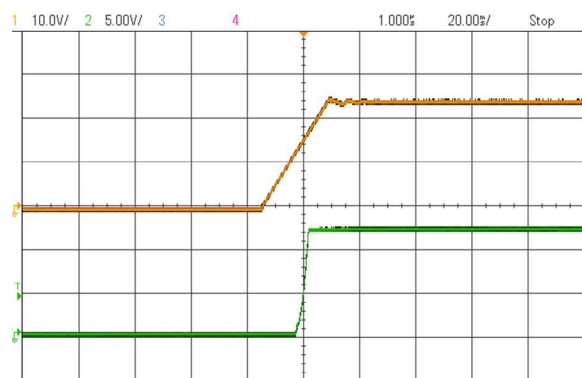

Performance Data

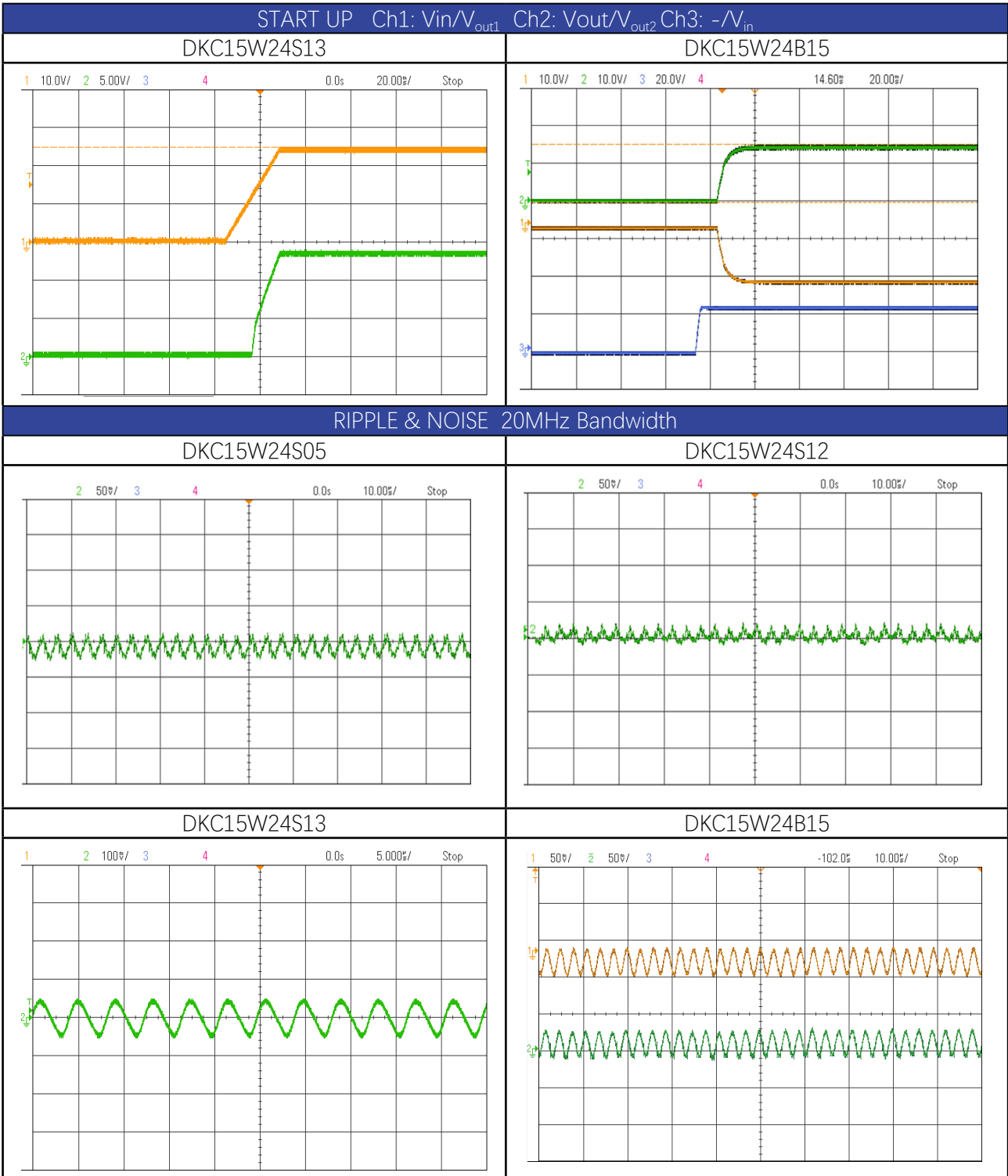

Performance Data

DYNAMIC RESPONSE (50%~75%~50% of I_{max} , $di/dt=1A/\mu s$)

Ch2: V_{out} Ch4: I_{out}

DKC15W24S05

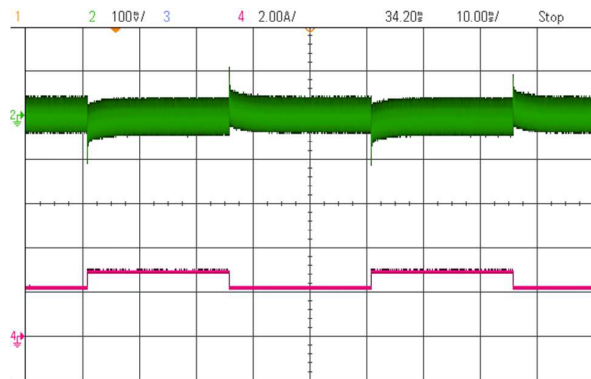

DKC15W24S12

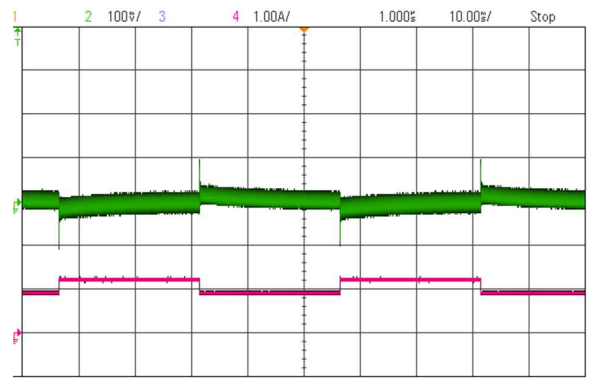

DKC15W24S13

Ch2: V_{out} Ch4: I_{out}

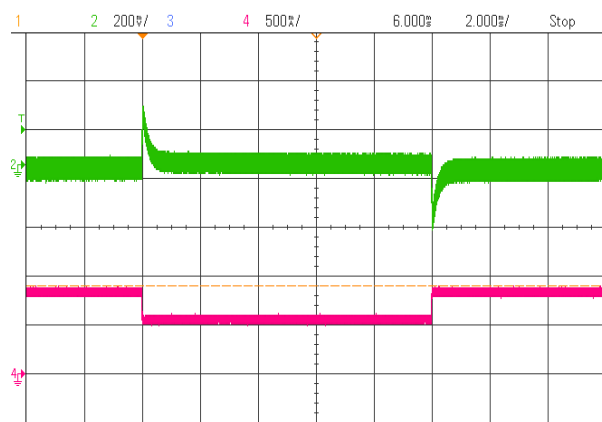

DKC15W24B15

Ch1: V_{out1} Ch2: V_{out2} Ch3: I_{out1} Ch4: I_{out2}

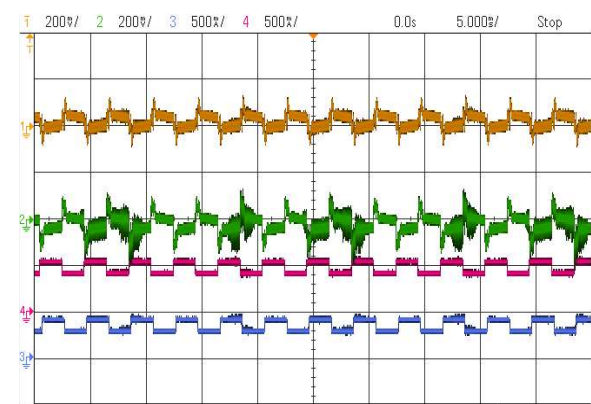

Mechanical Specifications

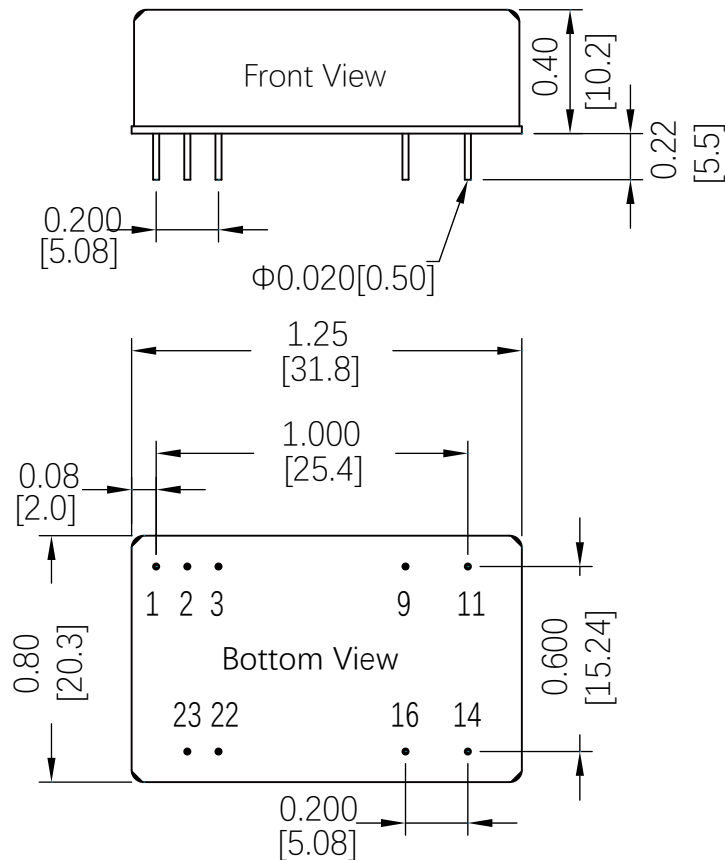

PIN:

PIN1, PIN2, PIN3, PIN9, PIN11, PIN14, PIN16,
PIN22, PIN23: $\Phi 0.020$ inch

Force: Applied force not exceed 4.9N

Material: Copper alloy

Finish: Gold 3 ~ $5\mu\text{m}$ (min.) over nickel $50\mu\text{m}$ (Min.)

Tolerance:

X.XX = ± 0.02 (0.5)

X.XXX = ± 0.010 (0.25)

Dimensions are in inches [mm]

Weight: ~20g.

*Note: Pin marked with NC means the module is equipped with Pin, but the Pin has no electrical function and is not allowed to connect any circuit.

PIN CONNECTIONS			
Single Output		Bipolar Outputs	
Pin	Function	Pin	Function
1	RC	1	RC
2	-Vin	2	-Vin
3	-Vin	3	-Vin
9	NC*	9	Common
11	NC*	11	-Vout
14	+Vout	14	+Vout
16	-Vout	16	Common
22	+Vin	22	+Vin
23	+Vin	23	+Vin

Mechanical Specifications

DKC15W24 SERIES: DIN-RAIL TYPE

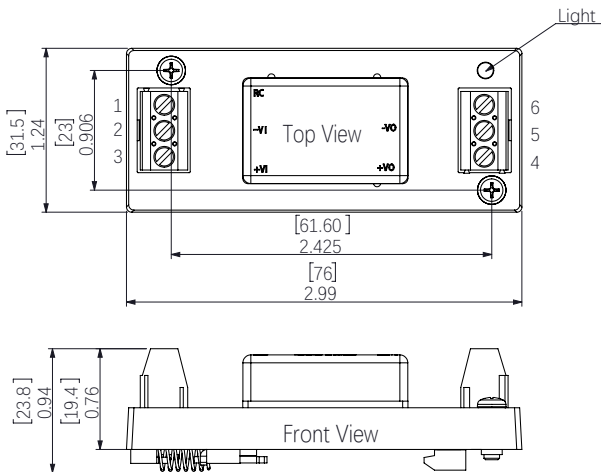

DKC15W24 SERIES: WALL MOUNT TYPE

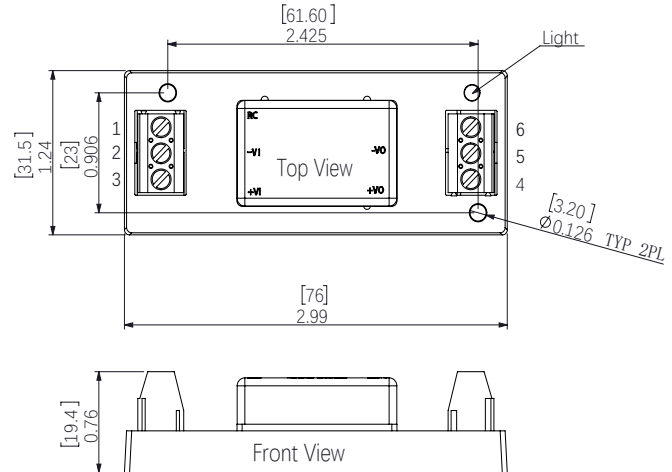

Hole screw locked torque: 0.4N·m Max
Terminal screw locked torque: 0.25N·m Max

Tolerance:
X.XX=±0.02 (0.5)
X.XXX= ±0.010 (0.25)

Dimensions are in inches [mm]
Weight: ~20g

PIN CONNECTIONS

Single Output		Bipolar Outputs	
Pin	Function	Pin	Function
1	RC	1	RC
2	-Vi	2	-Vi
3	+Vi	3	+Vi
4	+Vo	4	+Vo
5	-Vo	5	-Vo
6	NC	6	Common

Technical Notes

INPUT FUSING

Certain applications may require fuse at the inputs of power conversion components. Fuses should also be used when there is possibility of sustained input voltage reversal which is not current limited. The DKC15W24 modules are not internally fused. We strongly recommend a slow-blown fuse to be used in the ungrounded input supply line. For safety agency approvals, the installer must install the converter in compliance with the end user safety standard.

TYPICAL APPLICATION CONNECTION

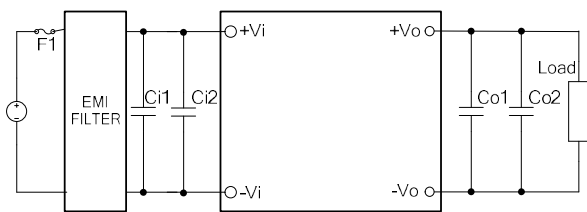

Figure 1: Typical Application Connection Single Output

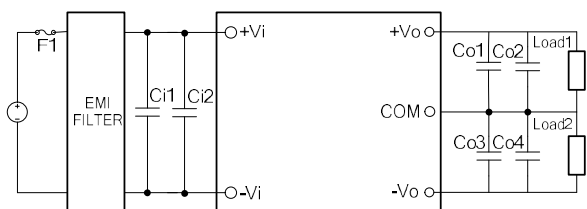

Figure 2: Typical Application Connection Bipolar Outputs

In order to prevent the input line from causing the input oscillation, it is recommended to add the input capacitor close to the input of the module. Similarly, the output capacitor is added to the output of the module. Specific recommended parameters: input capacitance $C_{i1}=100\mu\text{F}$ electrolytic capacitor, $C_{i2} = 1\mu\text{F}$ CBB capacitor. Output Capacitance $C_{o1}=10\mu\text{F}$ tantalum capacitor, C_{o2} ESR $<0.1\Omega$. For bipolar outputs, C_{o3} & C_{o4} are the same as C_{o1} & C_{o2} . Please refer to capacitive load for details.

REMOTE CONTROL FUNCTION

Module Power Remote Control or called ON/OFF pin is for the user to control the power output. DKC15W series adopt positive logic control. Recommend to use optocoupler to control remote pin as below.

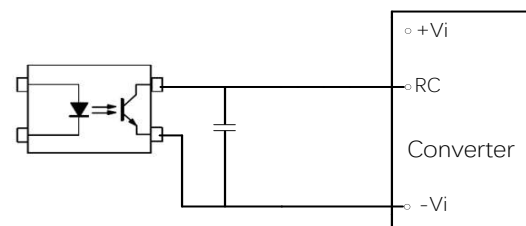

Figure 3: Remote Control Circuit

Remote Control Pin can be connected in parallel for multiple converters which with the same Remote Control characters. However, when several converters share the same remote control circuit, the total sink and source current must be taken into consideration, and make sure that the optocoupler has enough drive capability.

To reduce external PCB trace interference, it is recommended to add high frequency bypass capacitor between RC pin and $-V_i$, recommended capacitor value is 100-1000pF.

REFLECTED RIPPLE CURRENT

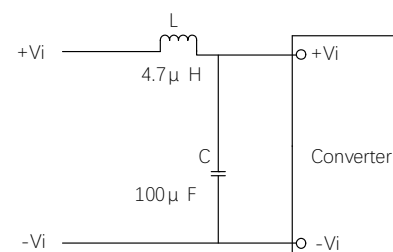

Figure 4: Reflected Ripple Current

Add LC filter at the front of the power module to reduce the interference of reflected ripple current on the DC bus, recommended value of L and C

Technical Notes

with appropriate current and voltage rating as below: $L=4.7\mu\text{H}$; $C=100\mu\text{F}$.

THERMAL SHUTDOWN

These DKC15W24 converters are equipped with thermal-shutdown circuitry. If environmental conditions cause the internal temperature of the converter to rise above the designed operating temperature, a precision temperature sensor will power down the unit. When the internal temperature decreases below the threshold of the temperature sensor, the unit will auto restart.

OUTPUT RIPPLE & NOISE

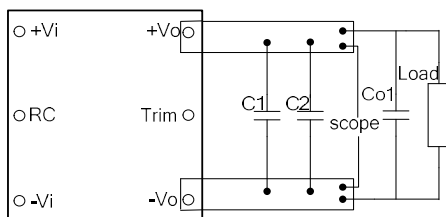

Figure 5- Output Ripple & Noise

These DKC15W24 modules' output ripple and noise is measured at the rated input voltage and output current, along with 10uF tantalum capacitor and 0.1uF MLCC used in parallel with appropriate voltage ratings and placed as C1&C2 shown in the figure above. The scope's bandwidth is set to 20MHz.

External output capacitors are required to reduce the ripple & noise. The output capacitors should be low ESR and appropriate frequency response with appropriate voltage ratings, and must be located as close to the converters as possible, also PCB layout must be taken into consideration.

INPUT UNDERVOLTAGE SHUTDOWN AND START-UP THRESHOLD

Once operating, module will not turn off until the input voltage drops below the Undervoltage Shutdown threshold. Subsequent re-start will not occur until the input is brought back up to the

Start-Up Threshold. This built in hysteresis prevents any unstable on/off situations from occurring at a single input voltage.

CURRENT LIMITING

The maximum current limit remains constant as the output voltage drops. However, once the impedance of the short across the output is small enough to make the output voltage drop below the specified Output Current Limit Shutdown Voltage, the converter turns off.

The converter then enters into "hiccup mode" where it repeatedly turns on and off until the short circuit condition is removed. This prevents excessive heating of the converter or the load board.

SHORT CIRCUIT CONDITION

When the converter is in current-limit mode, the output voltage will drop as the output current demand increases and then the converter will be shut down. If the short-circuit condition persists, another shutdown cycle will be initiated. This on/off cycling is referred to as "hiccup" mode. The hiccup cycling reduces the average output current, thereby preventing internal temperatures from rising to excessive levels. The module is capable of enduring an indefinite short circuit output condition.

OUTPUT OVERVOLTAGE PROTECTION

DKC15W24 output voltages are monitored for an overvoltage condition via magnetic feedback. The signal is coupled to the primary side and if the output voltage rises to a level which could be damaging to the load, the sensing circuitry will power down the PWM controller causing the output voltages to decrease. Following a time-out period the PWM will restart, causing the output voltages to ramp to their appropriate values. If the fault condition persists, and the output voltages again climb to excessive levels, the overvoltage circuitry will initiate another shutdown cycle.

Technical Specification

DKC15W24 Series

4:1 Wide Input, Isolated 15Watts DC/DC Converters



This product is subject to the following operating requirements and the Life and Safety Critical Application Sales Policy:

Refer to: <http://www.densitypower.com>

Density Power makes no representation that the use of its products in the circuits described herein, or the use of other technical information contained herein, will not infringe upon existing or future patent rights. The descriptions contained herein do not imply the granting of licenses to make, use, or sell equipment constructed in accordance therewith.

Specifications are subject to change without prior notice.